

Absolute encoders - bus interfaces

Blind hollow shaft $\varnothing 12$ mm

Magnetic single- or multiturn encoders 12 bit ST / 16 bit MT, DeviceNet

BMSH 42, BMMH 42 DeviceNet - MAGRES



BMMH 42 DeviceNet with blind hollow shaft

Features

- Mini encoder single- or multiturn / DeviceNet
- Magnetic sensing
- Resolution: singleturn 12 bit, multiturn 16 bit
- Housing $\varnothing 42$ mm
- Integrated fieldbus interface
- High resistance to shock and vibrations
- Resolution and zero point programmable

Technical data - electrical ratings

Voltage supply	10...30 VDC
Consumption typ.	100 mA (24 VDC, w/o load)
Initializing time typ.	170 ms after power on
Interface	DeviceNet
Profile conformity	Device Profile Encoder V 1.0
Steps per turn	≤ 4096 / 12 bit
Absolute accuracy	$\pm 1^\circ$
Sensing method	Magnetic
Code	Binary
Code sequence	CW default, programmable
Interference immunity	DIN EN 61000-6-2
Emitted interference	DIN EN 61000-6-3
Programmable parameters	Operating modes Total resolution Preset Scaling
Diagnostic functions	Position or parameter error Multiturn sensing
Approval	UL approval / E217823

BMSH 42

Function	Singleturn
----------	------------

BMMH 42

Function	Multiturn
Number of turns	≤ 65536 / 16 bit

Technical data - mechanical design

Size (flange)	$\varnothing 42$ mm
Shaft type	$\varnothing 12$ mm (blind hollow shaft)
Protection DIN EN 60529	IP 65
Operating speed	≤ 12000 rpm (mechanical) ≤ 6000 rpm (electric)
Operating torque typ.	0.0093 Nm
Materials	Housing: steel Flange: aluminium
Operating temperature	-20...+85 °C
Relative humidity	95 %
Resistance	DIN EN 60068-2-6 Vibration 30 g, 10-2000 Hz DIN EN 60068-2-27 Shock 500 g, 6 ms
Weight approx.	190 g
Connection	Connector M12, 5-pin Cable

Absolute encoders - bus interfaces

Blind hollow shaft $\varnothing 12$ mm

Magnetic single- or multiturn encoders 12 bit ST / 16 bit MT, DeviceNet

BMSH 42, BMMH 42 DeviceNet - MAGRES

Part number

Singleturn

BMSH 42S1N

24D	12/00		
-----	-------	--	--

				<u>Connection</u>
				5 Cable radial
				N Connector M12, 5-pin, radial
				<u>Blind hollow shaft</u>
		B2		$\varnothing 12$ mm, IP 42, with clamping ring
		P2		$\varnothing 12$ mm, IP 65, with clamping ring
				<u>Resolution</u>
	12/00			12 bit singleturn
				<u>Voltage supply / signals</u>
24D				10...30 VDC / DeviceNet

Multiturn

BMMH 42S1N

24D	12/16		
-----	-------	--	--

				<u>Connection</u>
				5 Cable radial
				N Connector M12, 5-pin, radial
				<u>Blind hollow shaft</u>
		B2		$\varnothing 12$ mm, IP 42, with clamping ring
		P2		$\varnothing 12$ mm, IP 65, with clamping ring
				<u>Resolution</u>
	12/16			12/16 bit single-/multiturn
				<u>Voltage supply / signals</u>
24D				10...30 VDC / DeviceNet

Accessories

Connectors and cables

10153968	Female connector M12, 5-pin, straight, without cable
11046264	Female connector M12, 5-pin, straight, 2 m cable
11046266	Female connector M12, 5-pin, straight, 5 m cable
10153969	Cable connector M12, 5-pin, CAN, straight
10153972	T-junction M12 CAN (1 male/2 female)
10153974	Terminating resistor CAN

Mounting accessories

10138610	Set of spring washers for BMSH, BMMH 42
10110616	Clamp set $\varnothing 15$ mm

Programming accessories

10147362	CD-ROM with GSD-/EDS-/XML files and user manuals
----------	--

Absolute encoders - bus interfaces

Blind hollow shaft $\varnothing 12$ mm

Magnetic single- or multiturn encoders 12 bit ST / 16 bit MT, DeviceNet

BMSH 42, BMMH 42 DeviceNet - MAGRES

Terminal significance

+Vs	Encoder supply voltage.
0 V	Encoder ground connection relating to +Vs.
CAN_L	CAN bus signal (dominant Low).
CAN_H	CAN bus signal (dominant High).
CAN_GND	GND relating to CAN interface.

DeviceNet features

Bus protocol	DeviceNet
Device profile	Device Profile for Encoders V 1.0
Operating modes	- I/O-Polling - Cyclic - Change of State
Preset	Parameter for setting the encoder to a requested position value assigned to a defined shaft position of the system. The offset of encoder zero point and mechanical zero point is stored in the encoder.
Rotating direction	Parameter for defining the rotating direction in which there have to be ascending or descending position values. Default setting: ascending position values when looking at the flange and rotating the shaft clockwise.
Scaling	Parameter defining the steps per turn as well as the total resolution.
Diagnosis	The encoder supports the following error warnings: - Position and parameter error - Lithium battery voltage control (Multiturn)
Default	125 kbit/s, Mac Id 63

Terminal assignment

Cable
for connection reference **-5**

Core colour	Signals	Description
brown	+Vs	Supply voltage
white	0 V	Supply voltage
green	CAN_H	Bus (dominant High)
yellow	CAN_L	Bus (dominant Low)
grey	CAN_GND	CAN Ground
pink	n.c.	–
blue	d.u.	do not use
red	d.u.	do not use
Screen	CAN_SHLD	CAN Shield
Cable data		8 x 0,14 mm ²

Connector M12 male

for connection reference **-N**

Connector	Signals	Description
Pin 1	CAN_SHLD	CAN Shield
Pin 2	+Vs	Supply voltage
Pin 3	CAN_GND	CAN Ground / 0 V
Pin 4	CAN_H	Bus (dominant High)
Pin 5	CAN_L	Bus (dominant Low)

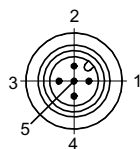

Absolute encoders - bus interfaces

Blind hollow shaft $\varnothing 12$ mm

Magnetic single- or multiturn encoders 12 bit ST / 16 bit MT, DeviceNet

BMSH 42, BMMH 42 DeviceNet - MAGRES

Dimensions

BMSH/BMMH 42 DeviceNet cable radial

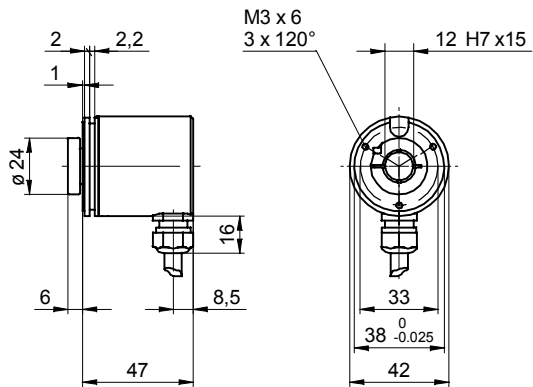

BMSH/BMMH 42 DeviceNet connector output radial

